

REV.	DESCRIPTION	DATE	BY

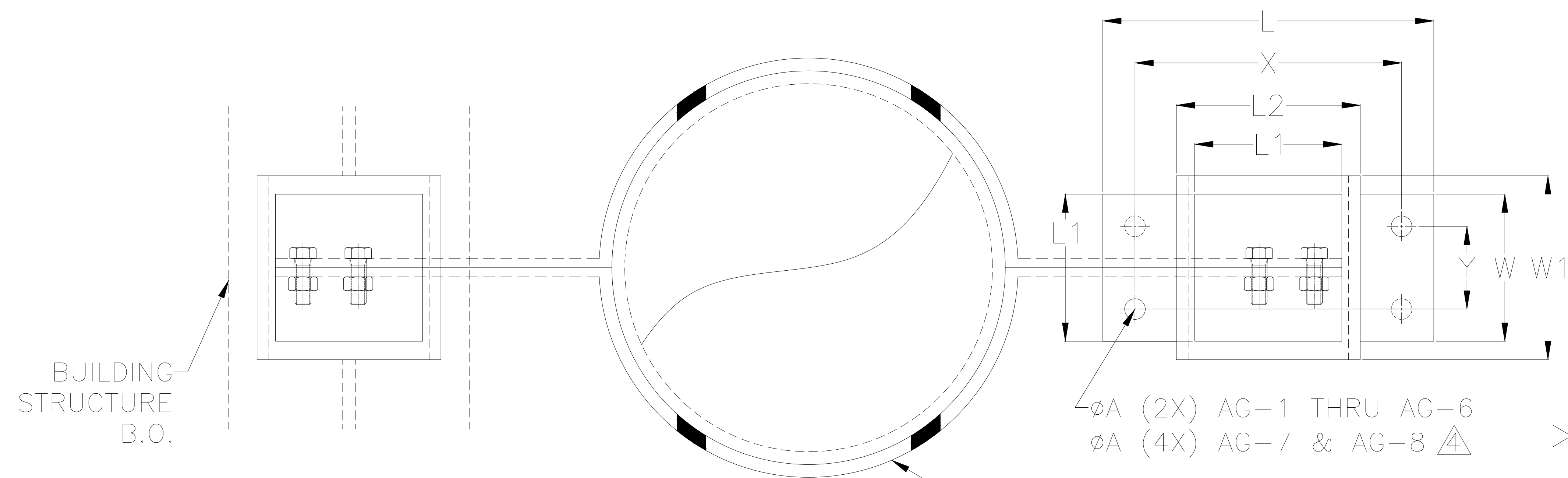

P/N	P/N WITH PLATE	MAX. LOAD RATINGS (LBS.)		DIMENSIONS (IN.)									
		VERT.	HORIZ.	H1	H2	L	L1	L2	W	W1	X	Y	ØA
AG-1	AG-1B	1000	500	3-3/16	4-1/16	6	2-1/2	3	3	3	4-1/4	1-1/4	5/8 (2X)
AG-2	AG-2B	1800	900	6	6-1/2	8-1/2	4	4	4	4-1/2	6-3/4	2-1/4	9/16 (2X)
AG-3	AG-3B	3000	1500	6-7/8	7-3/8	9	4	5	4	5	7-1/4	2-1/4	9/16 (2X)
AG-4	AG-4B	4200	2100	8	8-1/2	10	5	6	6	6	8-1/4	4-1/4	9/16 (2X)
AG-5	AG-5B	7500	3750	9-15/32	10-3/32	11	6	7	7	7	9-1/4	5-1/4	9/16 (2X)
AG-6	AG-6B	11800	5900	11	11-3/4	12-1/2	7	8	8	8	10-1/4	5-3/4	11/16 (2X)
AG-7	AG-7B	17000	8500	12-7/16	13-3/16	13-1/2	8	9	9	9	11-1/4	6-3/4	11/16 (4X)
AG-8	AG-8B	30700	15350	15-1/2	16-1/2	16	10	10	15	11	13-1/2	12-1/2	13/16 (4X)

* ISOLATOR CONSIST OF (2X) BOLT ASSEMBLY.

NOTES:

- LOAD RATINGS ARE PER AG ISOLATOR. MULTIPLY LOADS BY NUMBER OF AG ISOLATORS USED TO OBTAIN TOTAL ALLOWABLE LOAD.
- AG ISOLATORS BY THE VMC GROUP. PIPING ATTACHMENTS BY OTHERS.
- B.O.= BY OTHERS, NOT BY VMC
- REFER TO AG PRODUCT CUTSHEET 213R-104920 FOR ANCHOR HOLE QTY, SIZE, AND LOCATION.
- AG WELD TO BUILDING STRUCTURE AS PER WELD SPEC BY ENGINEER OF RECORD.
- WELDING SPECIFICATIONS BY OTHERS.

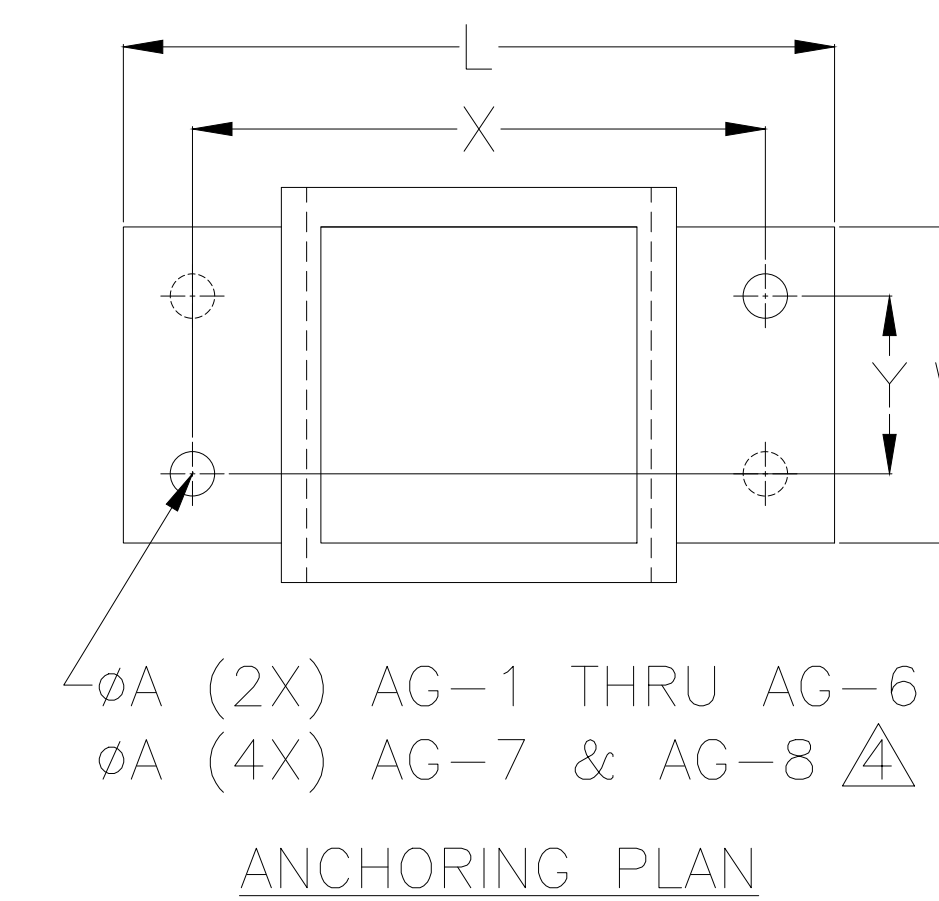
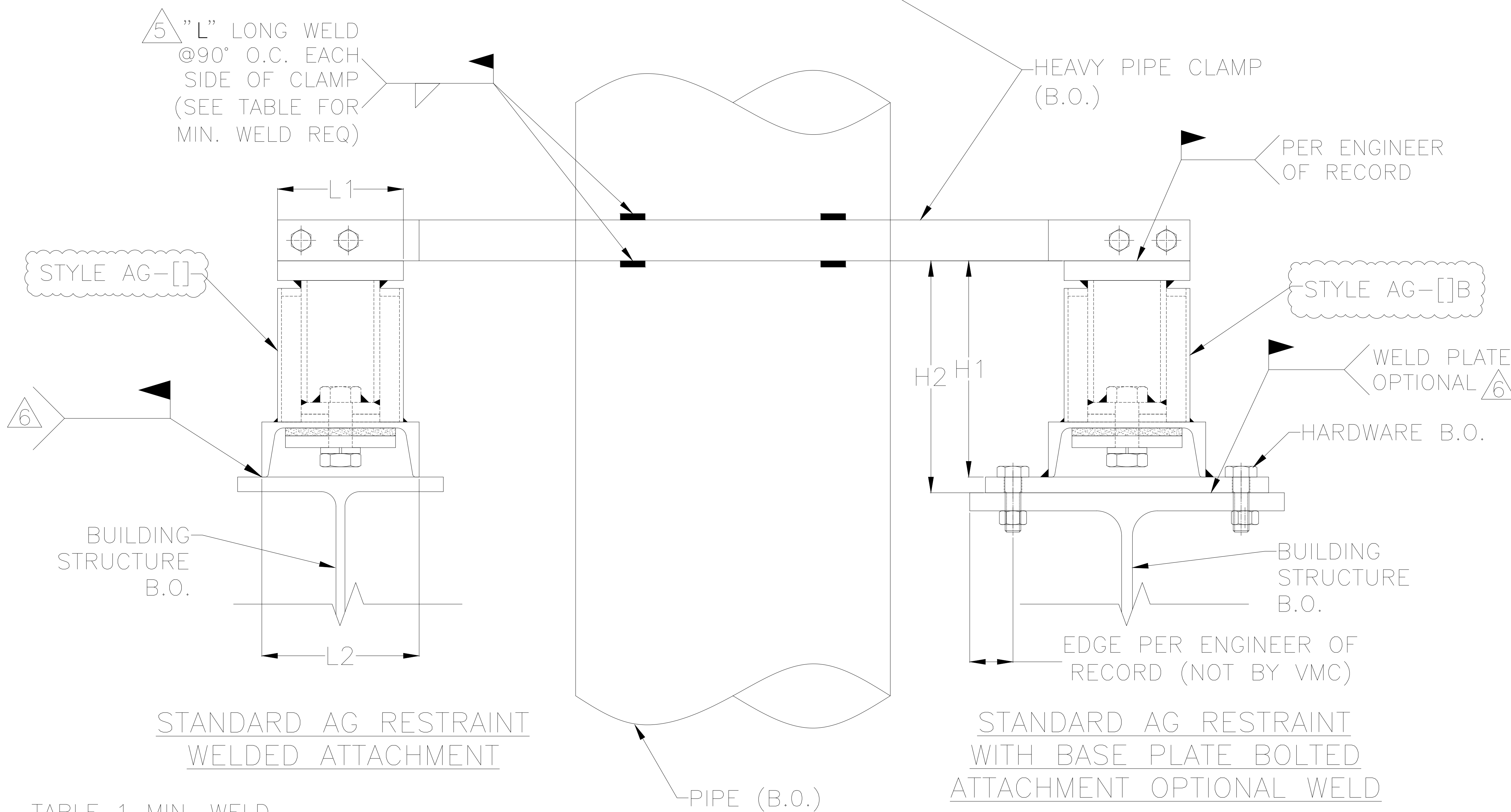

OTHER MATERIALS, COMPOUNDS, OR FINISHES WITH EQUAL OR SUPERIOR PROPERTIES MAY BE SUBSTITUTED AS THEY BECOME AVAILABLE.

TABLE 1 MIN. WELD

SIZE	L
AG-1	1"
AG-2 TO AG-6	2"
AG-7	3"
AG-8	5"



CERTIFIED FOR: CERT

JOB NAME: _____
 CUSTOMER : _____
 CUSTOMER P.O.: _____
 SALES ORDER: _____

MODEL AG RESTRAINT WITH & WITHOUT BASE PLATE FOR PIPE ANCHORING STEEL ATTACHMENT

VMC GROUP
 THE POWER OF TOGETHER
 Bloomingdale, NJ 07403
 Houston, TX 77041

SCALE : NONE
 SHEET: 1 OF 1
 DRAWING NO.: _____ REVISION _____

